

## Class AB Stereo Headphone Driver with Mute

### Features

- High Signal-to-Noise Ratio
- High Slew Rate
- Low Distortion
- Large Output Voltage Swing
- Flexible Mute Function
- Excellent Power Supply Ripple Rejection
- Low Power Consumption
- Short-circuit Elimination
- Wide Temperature Range
- No Switch ON/OFF Clicks
- Integrated Voltage Divider ( $V_{DD}/2$ ) to Eliminate External Resistors



### Applications

- Portable Digital Audio

### General Description

The APA3541/4 is an integrated class AB stereo headphone driver contained in an SO-8 or a DIP-8 plastic package with Mute feature. Besides the common Mute feature, the APA3541/4 further integrates a voltage divider inside the chip. Thus, the external resistors can be eliminated. The APA3541 has a fixed gain of 0dB and the APA3544 has a fixed gain of 6dB so that external gain setting is unnecessary. The device is fabricated in a CMOS process and has been primarily developed for portable digital audio applications.

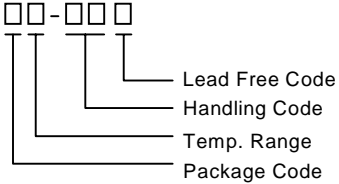
### Ordering and Marking Information

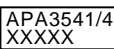
<p>APA3541/4 □□-□□□</p>  <p>Lead Free Code Handling Code Temp. Range Package Code</p>	<p>Package Code J : PDIP - 8      K : SOP - 8 Y : Chip From Temp. Range I : - 40 to 85 °C Handling Code TU : Tube      TR : Tape &amp; Reel Lead Free Code L : Lead Free Device      Blank : Original Device</p>
<p>APA3541/4 J : </p>	<p>XXXXX - Date Code</p>
<p>APA3541/4 K : </p>	<p>XXXXX - Date Code</p>

ANPEC reserves the right to make changes to improve reliability or manufacturability without notice, and advise customers to obtain the latest version of relevant information to verify before placing orders.

## Block Diagram

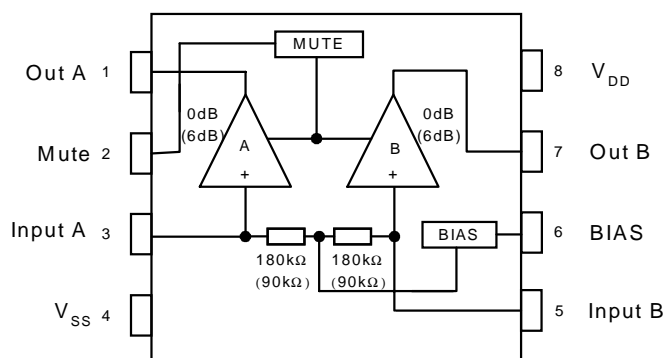

\* The values in parenthesis are for the APA3544.

## Function Pin Description

Pin Name	I/O	Function Description
Out A	O	A channel output pin
Mute	I	Chip disable control input, low active and high for normal operating
Input A	I	A channel input terminal
V <sub>SS</sub>		Power ground pin
Input B	I	B channel input terminal
BIAS	I	Right channel bias input pin
OUT B	O	B channel output pin
V <sub>DD</sub>		Power input pin

## Absolute Maximum Ratings

Symbol	Parameter	Rating	Unit
V <sub>DD</sub>	Supply Voltage	7	V
t <sub>SC(O)</sub>	Output Short-circuit Duration, at T <sub>A</sub> =25°C, P <sub>tot</sub> =1W	20	S
T <sub>A</sub>	Operating Ambient Temperature range	-40 to 85	°C
T <sub>J</sub>	Maximum Junction Temperature	150	°C
T <sub>STG</sub>	Storage Temperature Range	-65 to +150	°C
T <sub>S</sub>	Soldering Temperature, 10 seconds	300	°C
V <sub>ESD</sub>	Electrostatic Discharge	-3000 to 3000 <sup>*1</sup>	V

Note: 1. Human body model : C=100pF, R=1500Ω, 3 positive pulses plus 3 negative pulses

## Thermal Characteristics

Symbol	Parameter	Rating	Unit
$R_{THJA}$	Thermal Resistance from Junction to Ambient in Free Air	DIP-8	K/W
		SOP-8	
$R_{THJC}$	Thermal Resistance from Junction to Case	DIP-8	K/W
		SOP-8	

## Electrical Characteristics

$V_{IN}=0dBV$ ,  $V_{CC}=5V$ ,  $T_A=25^{\circ}C$ ,  $f=1kHz$ ,  $R_L=32\Omega$  (unless otherwise noted)

Symbol	Parameter	Test Condition	APM3541/4			Unit	
			Min.	Typ.	Max.		
$V_{DD}$	Supply Voltage		3.0	5.0	6.0	V	
$I_Q$	Quiescent Current	$V_{IN}=0$ Vrms		3.5	5	mA	
$I_{mute}$	Mute Current			200		$\mu A$	
$V_{TM}$	Mute Terminal Voltage		0.3	0.7	1.6	V	
$\Delta G_{VCL}$	Differential Channel Voltage Gain		-0.5	0	0.5	dB	
$G_{VCL}$	Voltage Gain	$V_{in}=1V_{rms}, f=1kHz, R_L=32\Omega$	APA3541	-2	0	2	dB
		$V_{in}=0.5V_{rms}, f=1kHz, R_L=32\Omega$	APA3544	4	6	8	
THD	Total Harmonic Channel Distortion Factor	$BW < 80kHz$		0.03	0.1	%	
$P_{U1}$	Rated Output Power1	$R_L=32\Omega, THD+N=0.1\%, BW < 80kHz$	APA3541	50	55	mW	
			APA3544	75	80		
$P_{U2}$	Rated Output Power2	$R_L=16\Omega, THD+N=0.1\%, BW < 80kHz$	APA3541	105	110	mW	
			APA3544	140	145		
$V_{NO}$	Output Noise Voltage	$BW=20\sim 20kHz, V_{in}=0V_{rms}$		-93	-85	dBV	
CS	Channel Separation	$F=1kHz$	APA3541	-90	-95	dB	
			APA3544	-65	-70		
ATT	Mute Attenuation	$V_{IN}=1V_{rms}, f=1kHz, Mute=L$	65	70		dB	
RR	Ripple Rejection	$F_{RR}=100Hz, V_{RR}=-20dBV$	50	60		dB	

## Test and Application Circuit

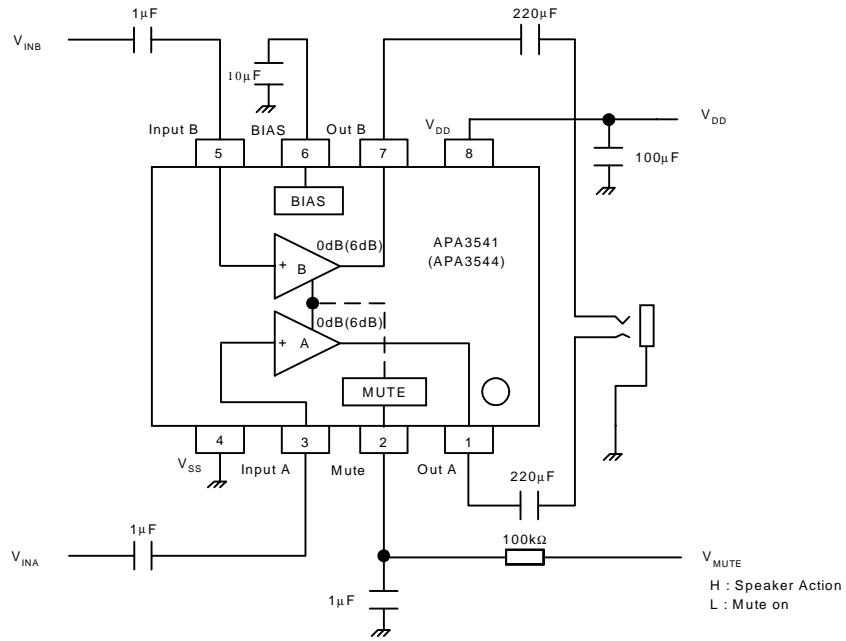

## Typical Characteristics

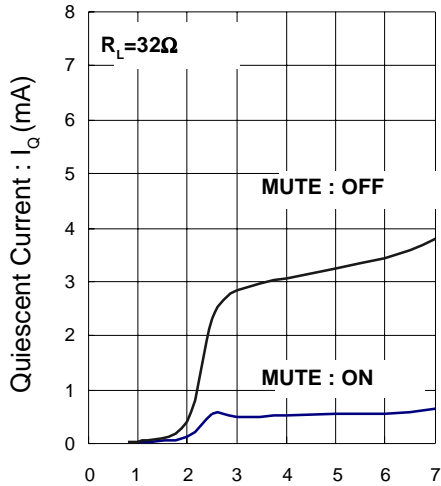

Figure 1 : Supply Voltage :  $V_{DD}$  (V)

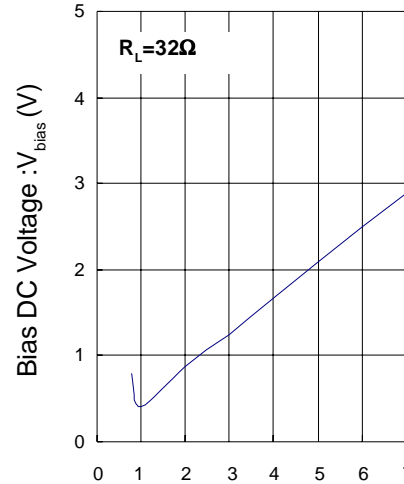

Figure 2 : Supply Voltage :  $V_{DD}$  (V)

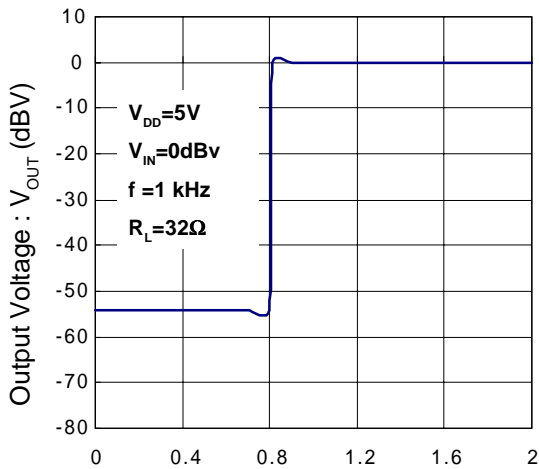

Figure 3 : Mute Control Voltage :  $V_{TM}$  (V)

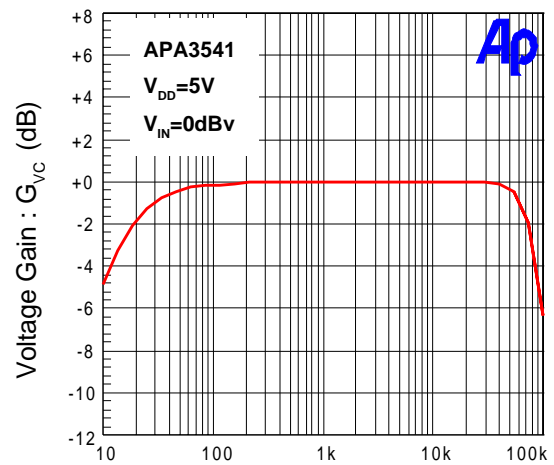

Figure 4 : Frequency :  $f$  (Hz)

Typical Characteristics Cont.

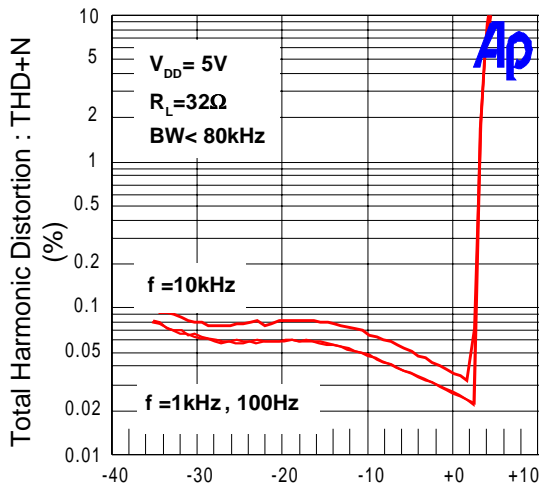

Figure 5 : Output Voltage :  $V_{OUT}$  (dBV)

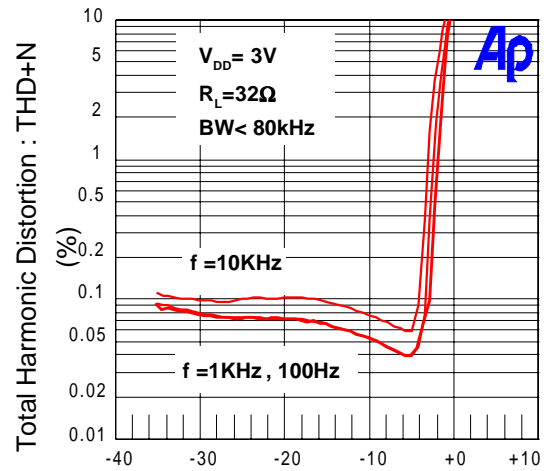

Figure 6 : Output Voltage :  $V_{OUT}$  (dBV)

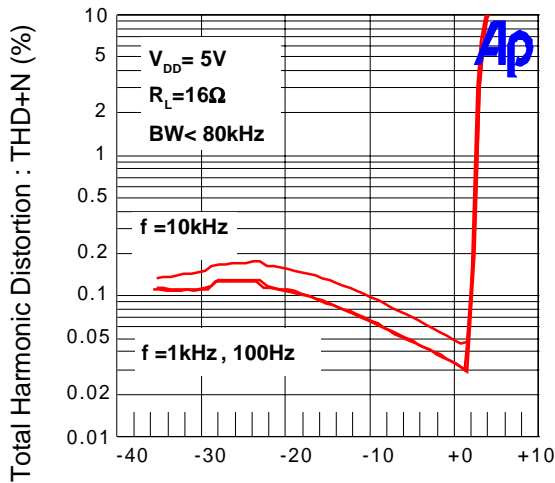

Figure 7 : Output Voltage :  $V_{OUT}$  (dBV)

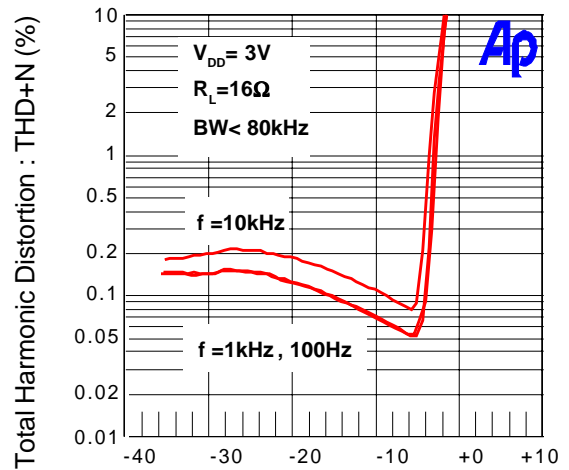

Figure 8 : Output Voltage :  $V_{OUT}$  (dBV)

Typical Characteristics Cont.

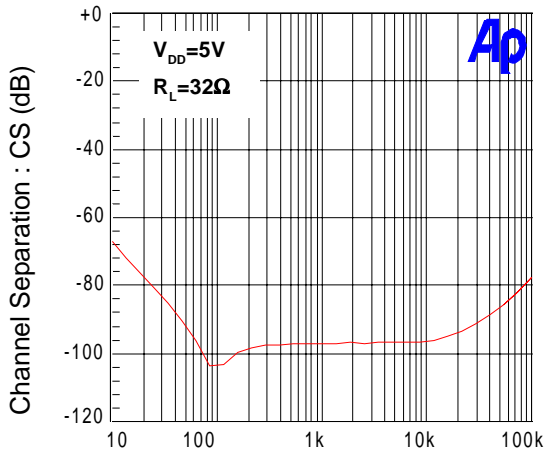

Figure 9 : Frequency :f (Hz)

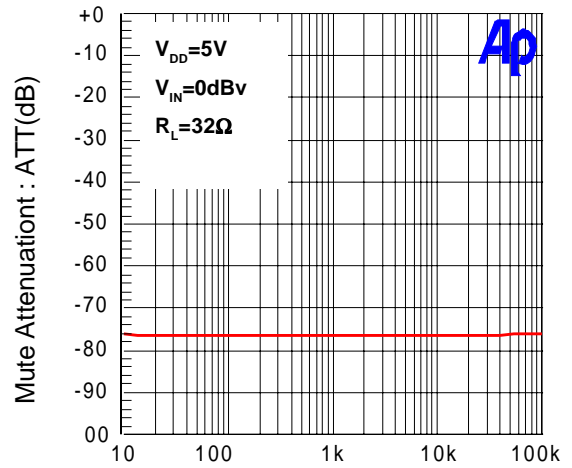

Figure 10 : Frequency :f (Hz)

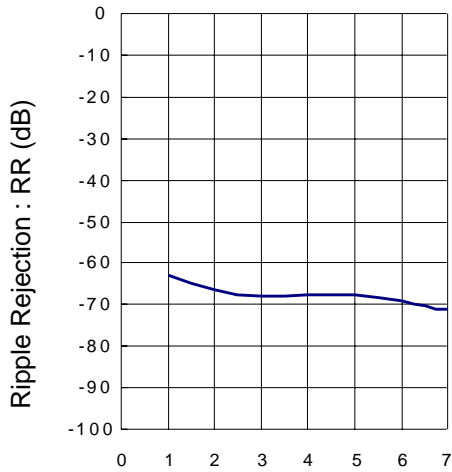

Figure 11 : Supply Voltage :  $V_{DD}$  (V)

## Application Note

### Input Capacitor , Ci

In the typical application an input capacitor , Ci , is required to allow the amplifier to bias the input signal to the proper DC level for optimum operation . In this case , the external capacitor Ci and the internal resistance Ri form a high-pass filter with the corner frequency determined in the follow equation:

$$f_c(\text{highpass})= 1/ (2\pi R_i C_i) \quad (1)$$

The value of Ci is important to consider as it directly affects the low frequency performance of the circuit. Consider the APA3541 where Ri is 180kΩ and APA3544 is 90kΩ internal fixed . Equation is reconfigured as follow:

$$\begin{aligned} C_i &= 1/(2\pi * 180k\Omega * f_c) \text{ for APA3541} \\ C_i &= 1/(2\pi * 90k\Omega * f_c) \text{ for APA3544} \end{aligned} \quad (2)$$

And the ceramic capacitor is recommended.

### Bias Capacitor , Cb

As with any power amplifier , proper supply bypassing is critical for low noise performance and high power supply rejection . The capacitor location on both the bypass and power supply pins should be as close to the device as possible . The effect of a larger half supply bias capacitor is improved PSRR due to increased half-supply stability . Typical applications employ a 5V regulator with 10μF and a 0 . 1μF bias capacitors which aid in supply filtering .

This does not eliminate the need for bypassing the supply nodes of the APA3541/4 . The selection of bias capacitors , especially Cb , is thus dependent upon desired PSRR requirements , click and pop performance . The capacitor is fed from a 95kΩ source inside the amplifier . To keep the start-up pop as low as possible , the relationship shown in equation should be maintained .

$$1/(C_b * 95k\Omega) \leq 1/\{C_i * R_i\} \quad (3)$$

As an example , consider a circuit where Cb is 4.7μF, Ci is 1μF and APA3541 Ri is 180kΩ . Inserting these values into the equation we get  $2.24 \leq 5.55$  which satisfies the rule . Bias capacitor , Cb , values of 2.2μF to 10μF ceramic or tantalum low-ESR ca-

pacitors are recommended for the best THD and noise performance .

### Output Coupling Capacitor, Cc

In the typical single-supply SE configuration , an output coupling capacitor (Cc) is required to block the DC bias at the output of the amplifier thus preventing DC currents in the load . As with the input coupling capacitor , the output coupling capacitor and impedance of the load form a high-pass filter governed by equation .

$$f_c(\text{highpass})= 1/(2\pi R_L C_c) \quad (4)$$

For example , a 220μF capacitor with an 32Ω speaker would attenuate low frequencies below 22Hz . The main disadvantage , from a performance standpoint , is the load impedance is typically small , which drives the low-frequency corner higher degrading the bass response . Large values of Cc are required to pass low frequencies into the load .

### Optimizing Depop Circuitry

When the amplifier is in mute mode , both of the output stage and input bypass continues to be biased . And no pop noise will be heard during the transition out of mute mode .

### Power Supply Decoupling, Cs

APA3541/4 is a high-performance CMOS audio amplifier that requires adequate power supply decoupling to ensure the output total harmonic distortion (THD) is as low as possible . Power supply decoupling also prevents the oscillations causing by long lead length between the amplifier and the speaker . The optimum decoupling is achieved by using two different type capacitors that target on different type of noise on the power supply leads . For higher frequency transients , spikes , or digital hash on the line , a good low equivalent-series-resistance (ESR) ceramic capacitor, typically 0.1μF placed as close as possible to the device V<sub>DD</sub> lead works best . For filtering lower-frequency noise signals , a large aluminum electrolytic capacitor of 10μF or greater placed near the audio power amplifier is recommended .



## Packaging Information

PDIP-8 pin ( Reference JEDEC Registration MS-001)

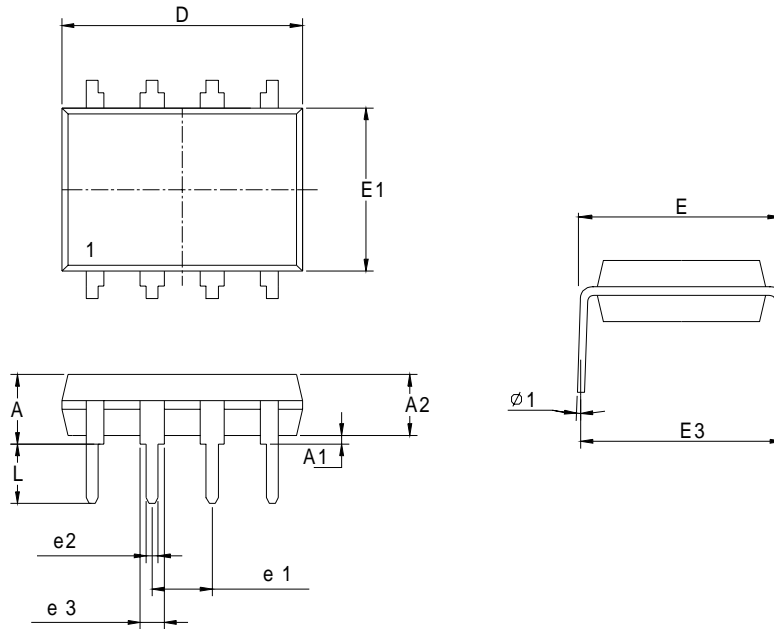

Dim	Millimeters		Inches	
	Min.	Max.	Min.	Max.
A		5.33		0.210
A1	0.38		0.015	
A2	2.92	3.68	0.115	0.145
D	9.02	10.16	0.355	0.400
e1	2.54BSC		0.100BSC	
e2	0.36	0.56	0.014	0.022
e3	1.14	1.78	0.045	0.070
E	7.62 BSC		0.300 BSC	
E1	6.10	7.11	0.240	0.280
E3		10.92		0.430
L	2.92	3.81	0.115	0.150
φ 1	15°		15°	

## Packaging Information

SOP-8 pin ( Reference JEDEC Registration MS-012)

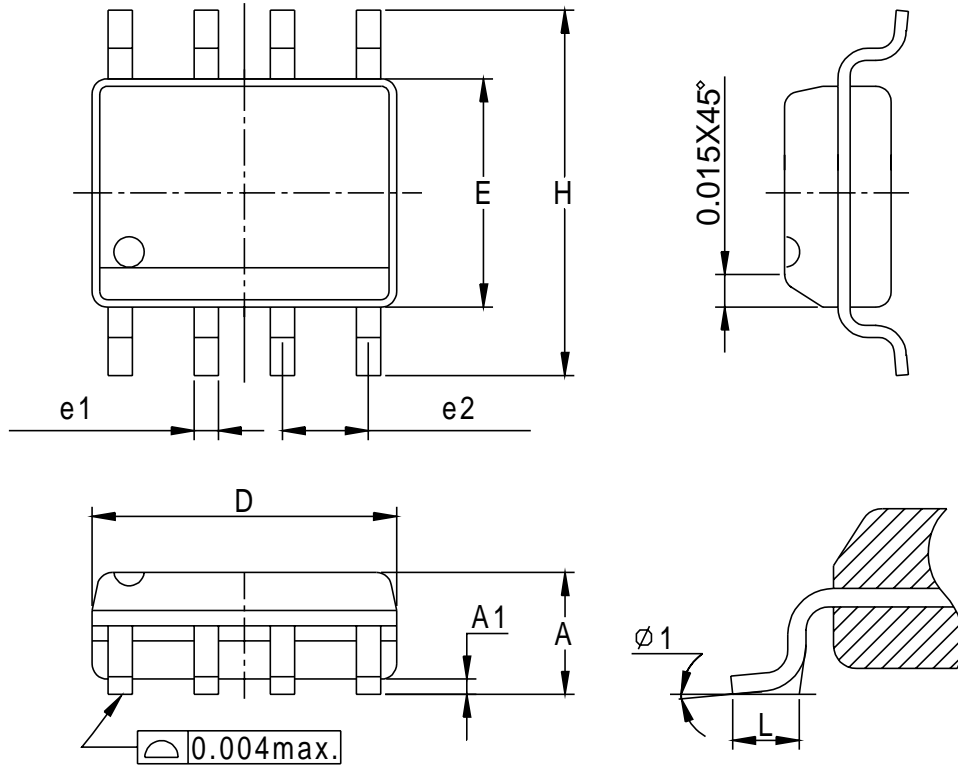

Dim	Millimeters		Inches	
	Min.	Max.	Min.	Max.
A	1.35	1.75	0.053	0.069
A1	0.10	0.25	0.004	0.010
D	4.80	5.00	0.189	0.197
E	3.80	4.00	0.150	0.157
H	5.80	6.20	0.228	0.244
L	0.40	1.27	0.016	0.050
e1	0.33	0.51	0.013	0.020
e2	1.27BSC		0.50BSC	
φ 1	8°		8°	

## Physical Specifications

Terminal Material	Solder-Plated Copper (Solder Material : 90/10 or 63/37 SnPb), 100%Sn
Lead Solderability	Meets EIA Specification RSI86-91, ANSI/J-STD-002 Category 3.

### Reflow Condition (IR/Convection or VPR Reflow)

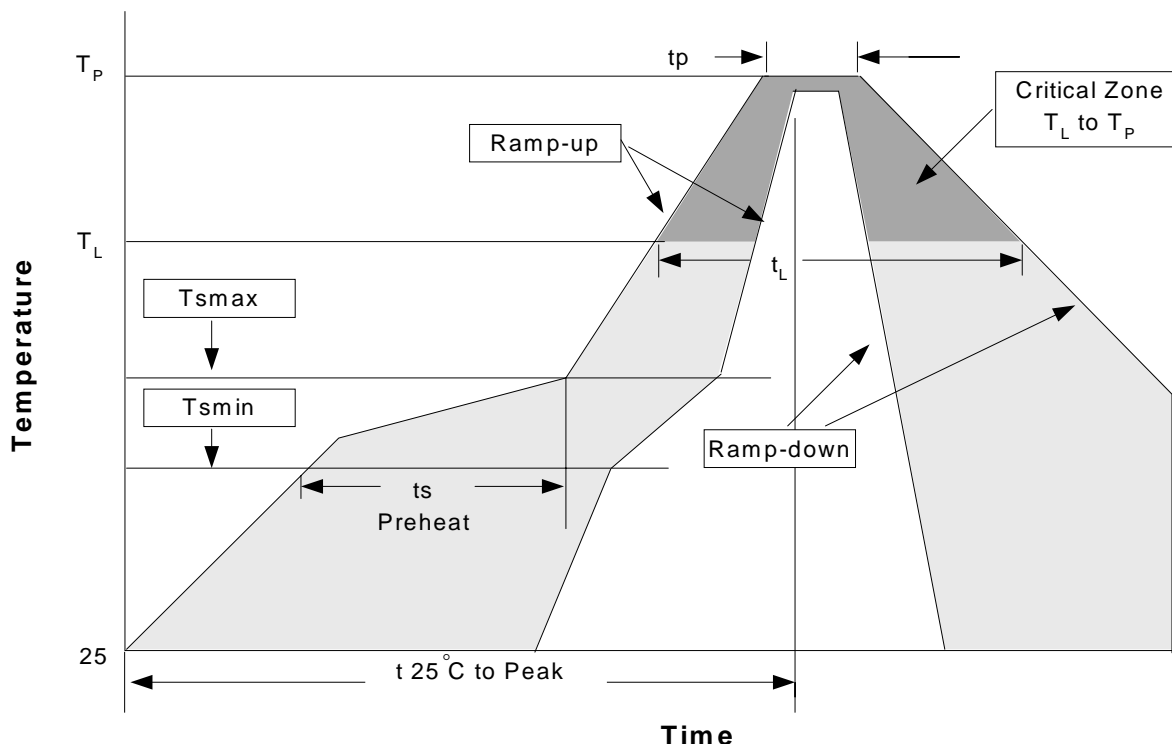

### Classification Reflow Profiles

Profile Feature	Sn-Pb Eutectic Assembly		Pb-Free Assembly	
	Large Body	Small Body	Large Body	Small Body
Average ramp-up rate (T <sub>L</sub> to T <sub>P</sub> )	3°C/second max.		3°C/second max.	
Preheat				
- Temperature Min (T <sub>smin</sub> )	100°C		150°C	
- Temperature Mix (T <sub>smax</sub> )	150°C		200°C	
- Time (min to max)(t <sub>s</sub> )	60-120 seconds		60-180 seconds	
T <sub>smax</sub> to T <sub>L</sub>			3°C/second max	
- Ramp-up Rate				
T <sub>smax</sub> to T <sub>L</sub>				
- Temperature(T <sub>L</sub> )	183°C		217°C	
- Time (t <sub>L</sub> )	60-150 seconds		60-150 seconds	
Peak Temperature(T <sub>p</sub> )	225 +0/-5°C	240 +0/-5°C	245 +0/-5°C	250 +0/-5°C
Time within 5°C of actual Peak Temperature(t <sub>p</sub> )	10-30 seconds	10-30 seconds	10-30 seconds	20-40 seconds
Ramp-down Rate	6°C/second max.		6°C/second max.	
Time 25°C to Peak Temperature	6 minutes max.		8 minutes max.	

Note: All temperatures refer to topside of the package. Measured on the body surface.

## Reliability Test Program

Test item	Method	Description
SOLDERABILITY	MIL-STD-883D-2003	245°C, 5 SEC
HOLT	MIL-STD-883D-1005.7	1000 Hrs Bias @125°C
PCT	JESD-22-B,A102	168 Hrs, 100%RH, 121°C
TST	MIL-STD-883D-1011.9	-65°C~150°C, 200 Cycles
ESD	MIL-STD-883D-3015.7	VHBM > 2KV, VMM > 200V
Latch-Up	JESD 78	10ms, 1 <sub>tr</sub> > 100mA

## Carrier Tape & Reel Dimensions

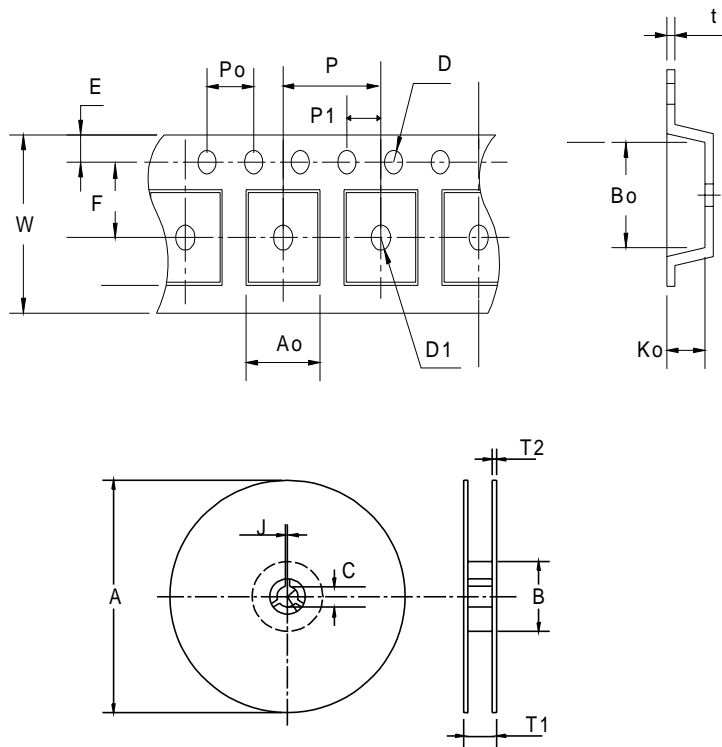

Application	A	B	C	J	T1	T2	W	P	E
SOP- 8	330 ± 1	62 +1.5	12.75+ 0.15	2 ± 0.5	12.4 ± 0.2	2 ± 0.2	12± 0.3	8± 0.1	1.75±0.1
	F	D	D1	Po	P1	Ao	Bo	Ko	t
	5.5± 1	1.55 +0.1	1.55+ 0.25	4.0 ± 0.1	2.0 ± 0.1	6.4 ± 0.1	5.2± 0.1	2.1± 0.1	0.3±0.013

(mm)

**Cover Tape Dimensions**

<b>Application</b>	<b>Carrier Width</b>	<b>Cover Tape Width</b>	<b>Devices Per Reel</b>
<b>SOP- 8</b>	12	9.3	2500

**Customer Service****Anpec Electronics Corp.**

Head Office :

5F, No. 2 Li-Hsin Road, SBIP,

Hsin-Chu, Taiwan, R.O.C.

Tel : 886-3-5642000

Fax : 886-3-5642050

Taipei Branch :

7F, No. 137, Lane 235, Pac Chiao Rd.,

Hsin Tien City, Taipei Hsien, Taiwan, R. O. C.

Tel : 886-2-89191368

Fax : 886-2-89191369